

45-0544KD

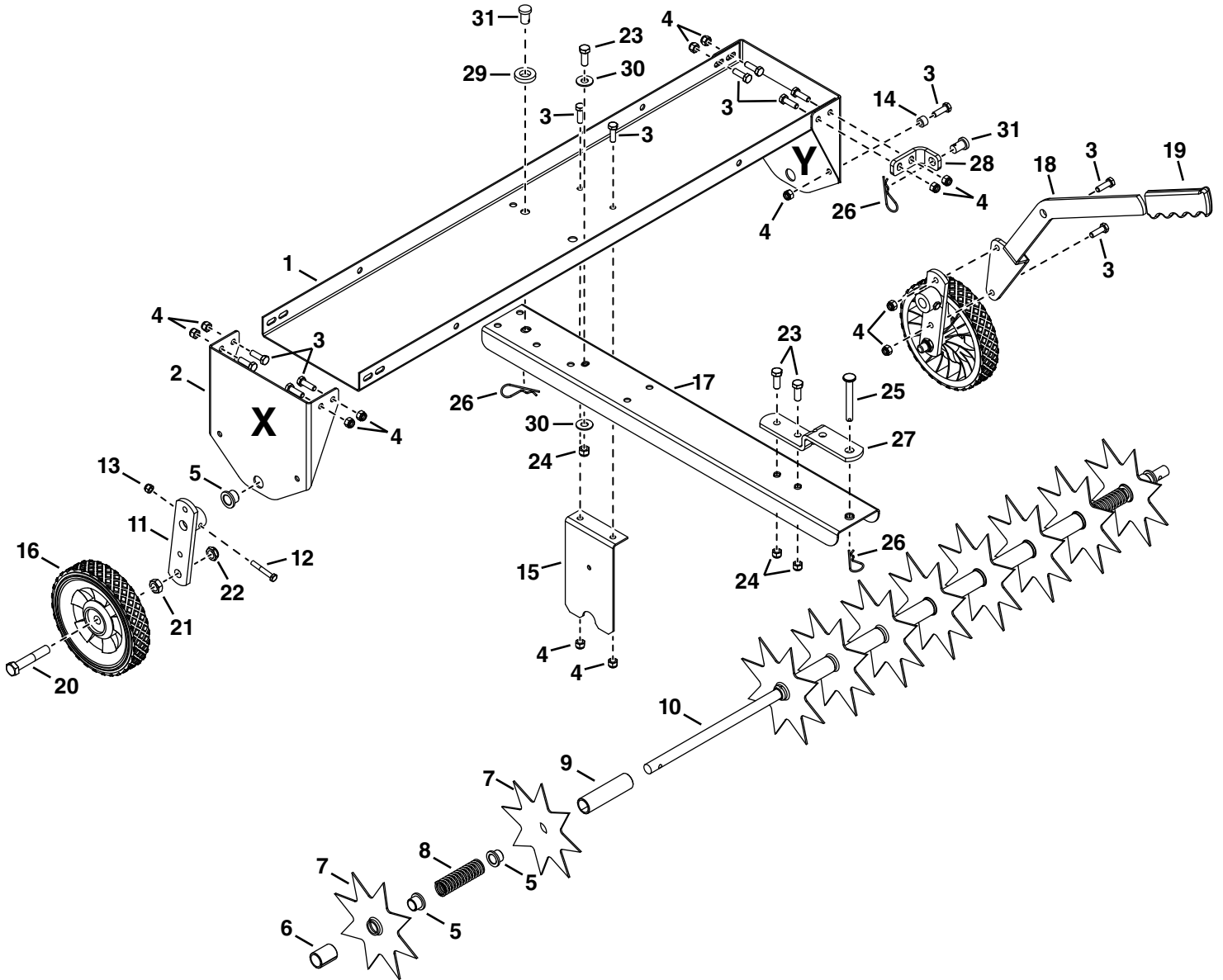

REF.	PART NO.	QTY.	DESCRIPTION	REF.	PART NO.	QTY.	DESCRIPTION
1	28304	1	Spiker Plate	17	28641	1	Drawbar
2	28303	2	End Plate	18	28306	1	Wheel Lift Handle
3	43063	15	Hex Bolt, 5/16 x 1"	19	43943	1	Grip
4	47810	13	Nylock Nut, 5/16"	20	43510	2	Hex Bolt, 1/2" x 2-3/4"
5	741-0249	12	Flanged Bearing	21	43019	2	Hex Jam Nut, 1/2"
6	44494	2	Spacer, 0.8" x 1"	22	48115	2	Nylock Jam Nut, 1/2"
7	28606	10	Galvanized Steel Spike Disk	23	43001	3	Hex Bolt, 3/8 x 1"
8	47777	2	Compression Spring	24	HA21362	3	Nylock Nut, 3/8"
9	45151	7	Spacer, 0.8" x 1" x 3.7"	25	47623	1	Hitch Pin
10	28309	1	Shaft	26	43343	3	Hair Cotter Pin
11	68774	2	Wheel Bracket Assembly	27	23687	1	Hitch Bracket
12	1509-69	2	Hex Bolt, 1/4" x 1-3/4"	28	28308	1	Handle Bracket
13	47189	2	Nylock Nut, 1/4"	29	23520	1	Spacer, 0.6" x 0.25" x 0.25"
14	23727	1	Spacer, 0.31" x 0.56" x 0.36"	30	43070	2	Washer
15	28331	1	Center Brace	31	42842	2	Clevis Pin
16	43021	2	Wheel		45738	1	Owner's Manual